



## SX-4 Specifications & Options

### ENGINE

- Tier 4i, Cummins® QSX15 450 hp (336 kW) @ 2,100 rpm

### WEIGHT

- Shipping weight..... 55,000 lbs (25,000 kg)
- Operating weight ..... 57,000 lbs (25,910 kg)

### ELECTRICAL SYSTEM

- CAN-based electronics
- Two 8D batteries
- 105 amp Alternator
- 24v System with master disconnect switch and emergency engine shutdown

### PROPEL SYSTEM

- 2-speed hydrostatic drive
- 4-wheel drive with differential lock

### SPEED

- Travel: 6 mph (10 kph)
- Work: 266 fpm (81 mpm)

### TIRES

- Heavy-duty, single-piece wheels prevent rim slippage and tire failure. High-flotation, deep tread 620/75 R26 tires.

### STEERING

- Joy stick-controlled. Four steering modes: coordinated steer, crab steer, front steer only, rear steer only.
- Turning radius: 14' (4,267 mm) in cut.

### OPERATOR STATION

- Fully enclosed and pressurized with A/C and heating system
- The cab can extend up to 18" (457 mm) to the right side of the machine

### INJECTION SYSTEM

- Water or emulsion
- Up to 500 gpm (1,893 lpm)

### CUTTER SYSTEM

- Multi groove v-belts
- Air Clutch
- 4 speed air shift transmission
- Planetary gearbox final drive with auto belt tension

### CUTTER

- Right-hand flush cut
- Cutting width..... 78" (2,000 mm) & 100" (2,540 mm)
- Cutting depth..... 16" (406 mm)  
with 50" drum (1,270 mm)
- Max cutting depth..... 20" (508 mm) (with 58" drum)  
with 58" drum (1,473 mm)

### CUTTER SPEEDS

- Number of speeds: 4
- Speed 1.....97 rpm
- Speed 2.....124 rpm
- Speed 3.....154 rpm
- Speed 4.....190 rpm



## SERVICE CAPACITIES

- Fuel Tank ..... 240 gal (908 l)
- Hydraulic Fluid Tank..... 50 gal (190 l)
- Air System..... 30 gal (114 l)

Cab can side-shift to the right 18" (457 mm)

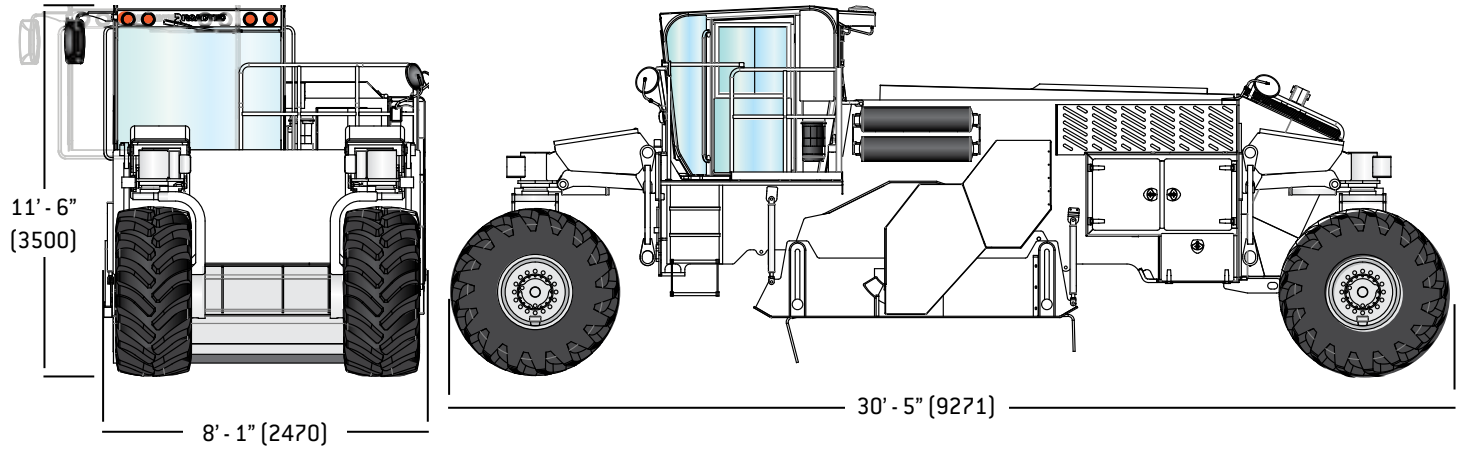

Dimensions in brackets are mm.

Specifications are subject to change without notice.

**ROADTEC** an Astec Industries Company

800 MANUFACTURERS RD • CHATTANOOGA, TN 37405 USA • 800.272.7100 • FAX 423.267.7104 • roadtec.com

130307



© 2013 Roadtec, Inc. All Rights Reserved