



# Highway-Class Pavers

## RP-190/195

### ENGINE

RP-190/195e: Tier 4F, Cummins® QSB6.7 230 hp (172 kW) @ 1,900 rpm  
RP-190/195ex: Tier 3; Cummins® QSB6.7 230 hp (172 kW) @ 1,800 rpm\*

*\* ex machines for lesser regulated countries*

### SHIPPING WEIGHT

RP-190: 36,700 lbs (16,646 kg)

RP-195: 39,220 lbs (17,789 kg)



### **Roadtec — An Astec Industries Company**

Roadtec, Inc. is proud to be a part of the family of companies that make up Astec Industries, Inc. Founded in 1972, Astec Industries, has grown to become America's leading manufacturer of equipment for asphalt road building, aggregate processing, oil, gas and water well drilling and wood processing. Roadtec continues to be an industry leader together with Astec Industries, by applying Astec's model of creative thinking bolstered by a corporate culture renowned for putting customer service first.



## THE ROADTEC DIFFERENCE: DELIVERING QUALITY AND INNOVATION WITH SUPERIOR CUSTOMER SERVICE

### **Dependability**

Roadtec has been manufacturing innovative, heavy-highway equipment since 1981. We continue to grow and add new products, yet our personal connection to our customers and our ability to respond immediately to your needs is even stronger.

### **Customer Service**

Our customers benefit from our strong focus on customer support after the sale. In-the-field service technicians live in the regions where they work and respond quickly. 24/7 parts support will get you the right parts fast, and at a fair price. Our product specialists will train your people on any newly purchased machine, and we also offer industry-leading training at our state-of-the-art training facility or in the field.

### **Count on Roadtec Equipment**

We don't build roads. We make the equipment so you can cost-effectively build and maintain the world's roads. With the Roadtec heavy-duty design, we are able to keep your machine working longer while lowering maintenance and operating costs. We are also able to make your operators more comfortable and confident with our user-friendly design and our customization for special projects.



## POWERFUL 10' PAVERS MADE FOR HIGHWAY WORK

### **RP-190: Rubber-Tire Paver**

Roadtec rubber-tired pavers have great maneuverability, ride quality, and traction. Two large rear drive tires are steered by two tandem bogie assemblies, and the offset bogie assemblies to increase the ground pressure gradually. Dry disc brakes on both wheels, hydraulic braking, and a parking brake give you precise control during operation.

### **RP-195: Rubber Track Paver**

The Roadtec track system gives a smooth ride on a large footprint with excellent flotation and traction. Smooth-tread rubber tracks are 18" (457mm) wide with one of the longest footprints available. An automatic hydraulic tensioning system keeps constant, even tension on the tracks, and oscillating bogies provide even pressure along the track and give a smooth ride.

### **Overview: RP-190/195**

The RP-190/195 are powerful, 10' (3 m) pavers made for highway work. Seats of the dual operator stations can move out beyond the sides of the machine to give the operator an excellent view down the sides of the machine. The fully adjustable operator seats feature a ride control tension system for ultimate comfort. Noise levels of Roadtec pavers are among the lowest in the industry thanks to variable speed fans. Roadtec pavers come equipped with standard fume extraction systems for the operator area.

Like all Roadtec pavers, the RP-190/195 features Roadtec's exclusive anti-segregation design of the feed tunnel, the feed tunnel discharge, and the rear augers.

# MADE FOR DURABILITY & PERFORMANCE WITH A STRONG FRAME AND EFFICIENT, COOL-RUNNING HYDRAULICS

## Solid Construction

All Roadtec asphalt pavers start with an extremely strong and rugged frame. The frame is completely fabricated, welded and assembled at the Roadtec facility, giving us complete control over the design and quality of the build. With its four inch thick (10 cm) front cross-member connected to two thick continuous side sheets that run the entire length and back of the paver, its extremely stable. Because of the solid construction and design, Roadtec pavers are able to withstand all of the forces involved with asphalt paving for a much longer time.



## Hydraulics and Cooling

The RP-190/195 use Sauer Danfoss® Series 90 hydraulic pumps for propel and material feed. These large easily serviced pumps allow the entire hydraulic circuit to run extremely cool greatly prolonging the life and lowering the maintenance costs of all components. The cooling package on Roadtec pavers is mounted on the side of the paver where it can get the cleanest and coolest air. Also access doors allow for improved airflow. The radiators are rated for higher horsepower engines and the fan is controlled hydraulically. The fan can run at the optimal speed depending on the load, which reduces noise levels emitted by the paver.



## DESIGNED WITH STRENGTH AND STABILITY FOR TOUGH JOBS



### Conveyors

The paver conveyors are designed to maximize throughput while maintaining durability. Each paver has a 13 inch high conveyor opening and wear resistant replaceable liners. Each conveyor is independently driven so material delivery can be fine tuned for each side. Finer control over the material is achieved since the conveyors are outfitted with their own feeder. Head and tail plates are made of chromium carbide-clad plate. Conveyor floor plates simply drop in, requiring no bolts.



### Augers

The 3/4" thick flights of the rear auger are made from cast, hardened steel. The rear augers also have an outer diameter of 16" (406 mm). The auger drive box is kept as narrow as absolutely possible to prevent centerline segregation. Outboard auger supports are well protected with ni-hard covers and temperature resistant bushings.



### Axles

One-piece axles for front bogies on the RP-190 go all the way through frame. No weld-on stub shafts. The one-piece axles add to the frame's strength and stability.



1. Roadtec uses one of the industry's strongest conveyor chains for durability & performance
2. Hinged, dual apron plates on the conveyors make clean out easy and convenient.
3. A solid steel push bar and roller assembly on the paver engages with loading vehicles. Note the thick front cross frame.

# INCREASED OPERATOR STATION COMFORT AND VISIBILITY BOOSTS PRODUCTIVITY AND SAFETY



## Visibility

The seats and controls mounted to the seat station hydraulically swing out past the side of the machine for increased visibility. This gives the operator infinite positions to choose from at the press of a switch and allows visibility down the side and to the back.

## Controls

All functions are easily accessible, including feed system and flow gate controls. Track models use a single joystick for all propel functions. A tilt steering wheel controls rubber tire pavers.





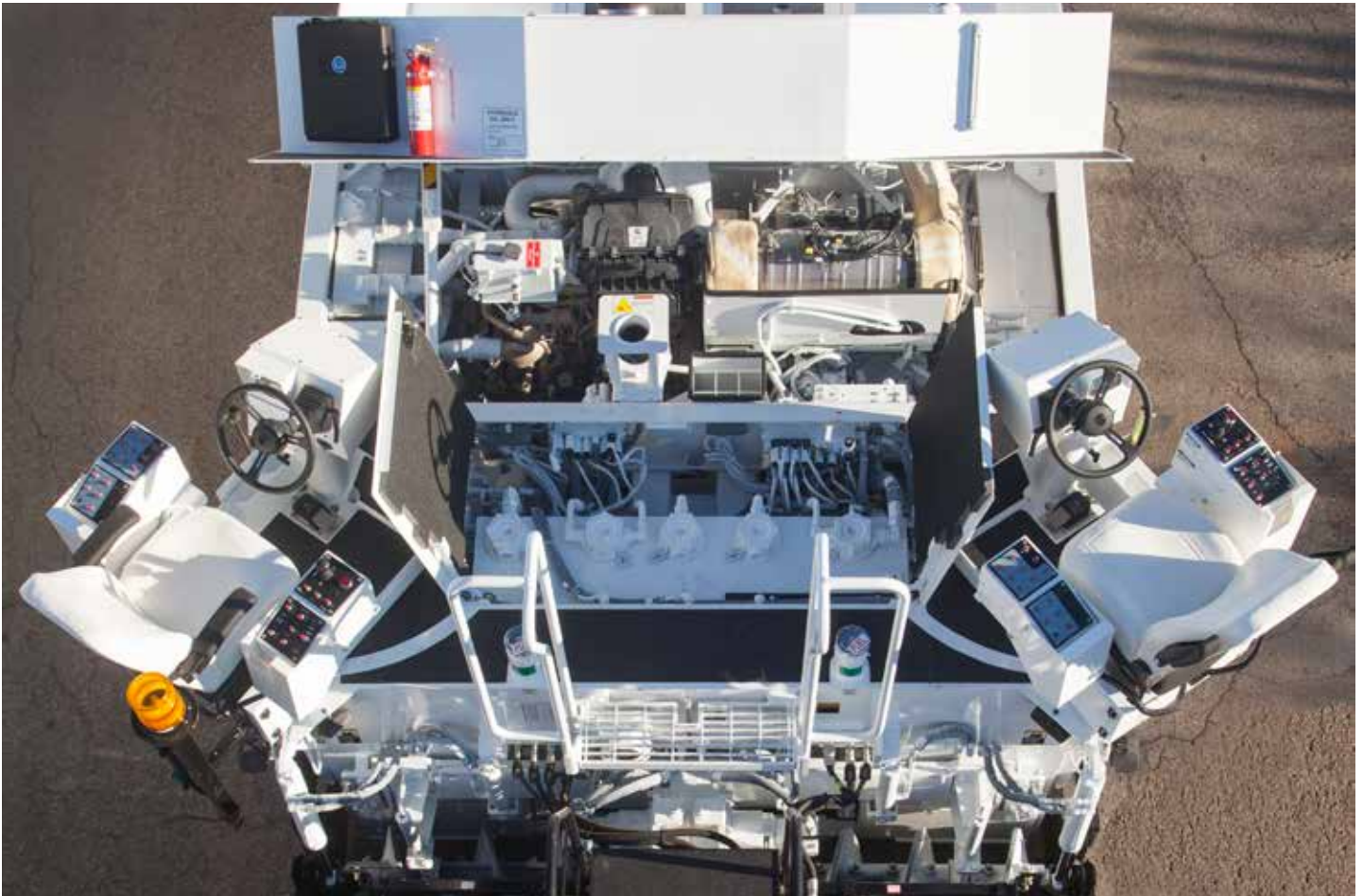

## DUAL OPERATING CONTROL SYSTEMS ON LEFT AND RIGHT SIDES OF THE PAVER ARE DESIGNED TO ELIMINATE FATIGUE

### **Safety & Convenience**

Roadtec pavers are equipped with numerous safety features. Emergency shut-off switches are found at ground level on both screed boxes and at the main operator stations. Roadtec is the only paver manufacturer to provide disc brakes on rubber-tired machines. With the greatly reduced noise levels and improved visibility, Roadtec pavers allow the operator to stay in constant visual and audible communication with the rest of their crew.

### **FXS™ Fume Extraction**

Roadtec uses two fans to draw any fumes emitted by the asphalt mix away from the crew. Fumes and exhaust are directed away through vents at the front of the engine hood. This large amount of air moving over the hopper keeps the platform fume-free and cool.

# PROTECT YOUR INVESTMENT AND KEEP OPERATING COSTS LOW BY MONITORING YOUR MACHINES IN REAL TIME

The Roadtec Guardian™ Telematics System consists of software, on-machine viewing screens, and wireless signal boosters to send from and receive data at the machine. The information can be viewed at the machine or on your computer screen from a remote location.

Numerous other functions can also be viewed. Roadtec Guardian Telematics System is standard on 10' pavers. Software is automatically updated when a new version is released.



## Monitor & Troubleshoot

- Grade and Slope
- Hydraulics
- Engine
- GPS Location
- Machine Codes
- Screed Heat
- Machine Speeds
- Screed Operations
- Fuel Usage
- And Many More

## By Roadtec for Roadtec

Guardian™ Telematics is for Roadtec customers who are looking to dramatically lower operating costs and increase productivity.

## Access Guardian™ Remotely

Log into the machine from any Internet connected computer to view machine data remotely.

## Know What's Happening

Designate someone of your choice to receive auto e-mails that the Guardian™ Telematics System sends out about any fault codes that may be generated. Your people can then log on to the machine and address the problem. You can also call Roadtec Service, and one of the Roadtec service techs can dial into the machine to confirm and solve issues.

## Benefit Your Bottom Line

Save on sending mechanics out into the field to find issues. Minimize the time the machine is down with the ability to isolate and fix problems within minutes. Increase machine life and uptime by never missing a scheduled maintenance. Eliminate false alarms and wasted trips.

**Your machine can be located by GPS using the Guardian™ Roadtec Telematics system.**

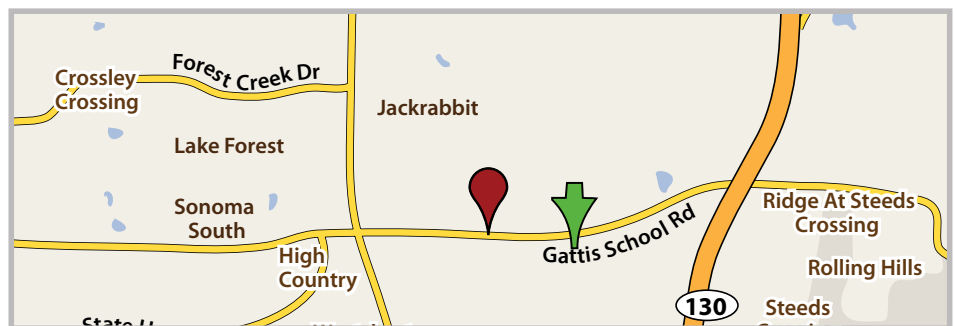



# DURABLE, ABRASION RESISTANT COMPONENTS COMBAT SEGREGATION AND LOWER OPERATING COSTS

## **Electric Flow Gates Lead to Proper Distribution of Material**

Roadtec pavers have electric flow gates that are simple to operate and give precise control over the head of material in any situation allowing material to be properly distributed without burying the auger and flooding the middle. Flow gate positions are displayed at every control box.

## **Uniform Flow**

Each rear auger and conveyor is driven by its own hydraulic motor. This way conveyors can be wider and closer together. Each side can be run independently. Mix is conveyed out as one uniform flow, which greatly reduces segregation. Conveyor drive motors can be controlled independently of the augers by screed operators to decrease the pile at the end of each pull.

## **Auger Assembly**

The auger assembly on Roadtec pavers can be hydraulically raised, lowered and tilted. This feature can assist in eliminating segregation in certain mixes and is very helpful during the loading and unloading process as well as constructing "supers". Standard sonic feed sensors control each side of the feed system.

## DELTA PLATE AND CLOSE PROXIMITY OF AUGERS TO CONVEYORS

The Delta Plate defines the front wall of the material tunnel, preventing mix from rolling forward under the paver, a main cause of centerline segregation. It also removes mix from the conveyors providing better conveyor efficiency. The augers are kept very close to the discharge of the conveyors so that material is always kept live and moving and not just dumped on the ground.



## EASY AND SAFE ACCESS FOR CLEANING, INSPECTION AND MAINTENANCE



### **Unsurpassed Access**

All maintenance and inspection areas are easily reached through access doors on the sides and top of the pavers. The hood lifts hydraulically and has a manual lift back-up feature. The engine compartment is roomy enough to make component access convenient. The hydraulic oil tank is located under hinged doors on the operator platform. The cooling radiator for hydraulic oil and fuel can pivot out for easy cleaning and inspection. A second radiator, on the opposite side of the machine, cools charge air and engine coolant.



1. Easily reach the electrical box from the ground.
2. Sensors continuously monitor hydraulic pressures and the values are easily accessible on the operators display console.

3. Large access doors with honeycomb pattern grates allow for improved airflow and complete access to the engine. Additional access doors are found at each service point.

4. A retractable hose for spray-down is standard as well as a release agent reservoir.

# SCREEDS WITH THE LATEST TECHNOLOGY AND FEATURES ENSURE SUPERIOR PERFORMANCE

## To Build a Better Road You Need a Better Screed

Roadtec offers you screeds that are simpler to operate and maintain than competing brands and are much more rugged and functional. That's why professional road builders rely on Roadtec and Carlson screeds time and time again. Each of the six model series comes in 8 foot (2.4 m) and 10 foot (3.0 m) versions with a variety of extension options. The screeds can be operated with single or dual grade control mode, grade and slope control, or manually. All our screeds are designed and built in the U.S.

## Electric Heat The Right Way

Screed plates on all models are heated electrically. Just set the thermostat to the temperature you want. Changing out heating elements shouldn't take all day. You'll appreciate the fact that you can remove and replace the heating elements through a side access door above the main screed plate. There's no need to take off the whole plate. The elements themselves are heavy-duty, both in structure and performance; so they'll last a long time. You can get replacements off the shelf at industrial supply houses or from Roadtec Parts. A 34 kW generator powers the elements and also provides plenty of extra current for other electrical needs. Outlets for plugging in other electrical devices are provided.

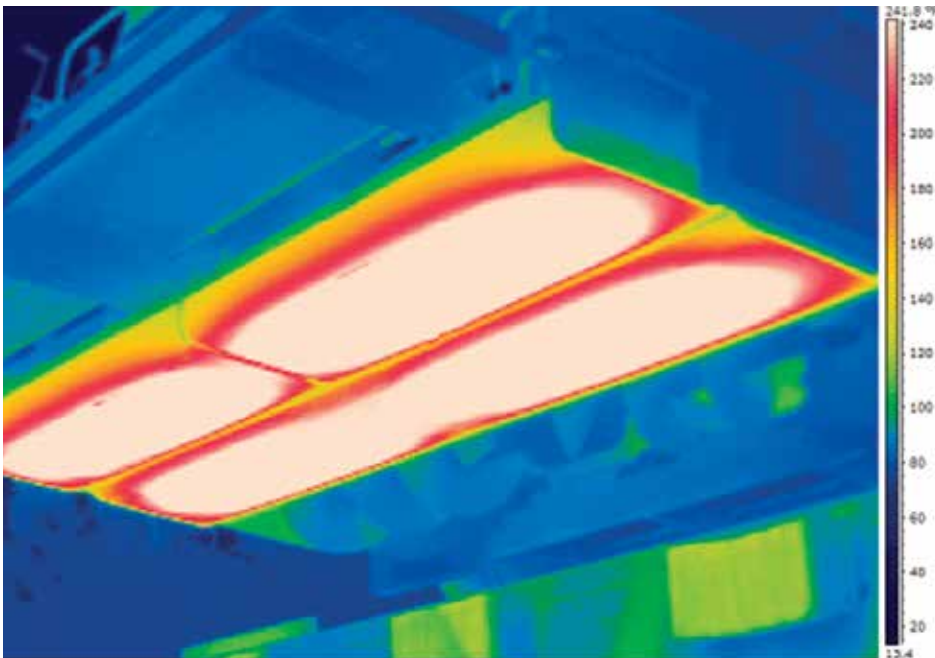

- With the unique way we distribute heat above the screed plate, we can assure you even temperatures front to back and side to side.
- Heat is distributed evenly across the plate. The heating elements are heavy-duty and only need to run at 1/3 rated capacity to keep the screed hot.





**1** Adjustable pre-strikeoffs are standard on all our main screeds as well as on Eagle® series and Carlson extensions.

**2** Dual control stations with lockable vandal covers secure on-board.

**3** A variety of contacting and non-contacting grade and slope controls are offered.

**4** Outlets for lights or tools.

**5** Two-piece, spring-loaded endgates handle grade changes.

**6** Extra-wide walkways

## ROADTEC OFFERS SEVERAL SCREED OPTIONS FOR BOTH 8 FT AND 10 FT PAVERS



### **The Roadtec Eagle Screed: Heated, Vibratory Rear Extensions**

The Eagle® screed combines the latest in screed technology and heavy-duty structural design to bring you this top-of-the-line series. Heated, vibratory rear extensions let you achieve smoothness specs with ease. Thanks to the exclusive Roadtec subframe, the time it takes to remove the screed plate is half that of conventional designs. And reversible, U-shaped plates are extra stiff for a consistent mat. Those are just a few of the advantages of an Eagle screed. Add superior control features and better visibility, and you can't go wrong with this one.

### **Eagle Screed Highlights**

Trailing (rear-mounted) extensions favor more even compaction across the mat. It's the preferred design to use when consistent mat density is key. The Eagle rear-mounted vibratory hydraulic extensions move on dual guide tubes and greaseless Teflon® bushings.

Both edges of the Eagle screed plate are curved. You can turn the plate around for a fresh leading edge and twice the wear life. That's true of extension plates, too. Adjustable pre-strikeoffs on the main screed and the extensions come in especially handy for thin-lift paving. The Eagle 8 end gates can be swung in for shipping to narrow the load to 8 feet (2.5 meters).

## S-Series Screeds: Fixed width bolt-on extendable screeds

Roadtec's fixed width bolt-on extendable screeds with hydraulic strikeoffs come in an 8 foot (2.5 m) version or 10 foot (3 m) version. Strikeoffs can be articulated from 6.6% positive to 3.3% negative. These tough, reliable screeds will serve you well for a wide range of projects.



## The Carlson EZ Series: Front Extensions and Tapered Plates

The EZ Series from Carlson features electrically heated vibratory screed plates and extensions. The patented, tapered shape of the Carlson main screed plate assures that material is moved toward the outside for a uniform mat no matter whether extensions are in or out. Carlson EZ screeds also feature a food-warming oven to heat crew meals. Carlson EZIV-8 and EZIV-10 screed extensions support system uses high-strength chrome rods with adjustable composite bushings to maintain tight controls and prevent vertical movement of the extension. With an extended paving width of 15 feet (4.57 m) for the EZIV-8 and 19 feet (5.79 m) for the EZIV-10, these quick-reacting screeds are ideal for commercial paving.





## OPTIONS

### Additional Lighting

- Night Light Package – (6) 24v
- Airstar Balloon Light Assembly – (2) 500W halogen bulbs, fan, telescoping pole, two brackets & case.
- Laser Pointer Alignment Guide - High intensity laser mounted to tractor can be positioned along line of travel to aid operator in aligning paver correctly.
- SaberLight™ - (2) 92W, light panels Truck Dump Signal Light – LED signal light to indicate to truck driver whether to dump, stop, or lower
- Additional amber beacon

### Front Wheel Assist - RP-190

- Additional hydraulic motors on both rear bogies. Also available as retrofit.

### Tunnel Extensions

- 12" (305 mm) tunnel extensions
- 18" (457 mm) hydraulic tunnel extensions

### Auger Extensions

- 12" (305mm), 0.75" (19mm) thick ni-hard auger extensions. Right-hand or left hand.

### **6' (1,829mm) Auger & Tunnel Extension Package**

- 36" (914 mm) auger and tunnel extensions for each side. Comes with all necessary hardware including outboard auger bearing supports and tunnel extension braces. Additional 12" (305 mm) auger and tunnel extension segments can be added to each side. Does not include any screed extensions.

### **20.5' (6,248mm) Auger & 20.75' (6,325mm) Tunnel Extension Package**

- Extends augers to 20.5' (6,248 mm) and tunnels to 20.75' (6,325 mm). Additional 12" (305 mm) auger and tunnel extension segments can be added to each side for total of 22.5' (6,858 mm) of augers and 22.75' (6,934 mm) of tunnels.

### **Reversing Distribution Augers**

- Retrieve material when bringing extensions in

### **Hopper Insert**

- For use with Shuttle Buggy® MTV

### **Lubrication**

- Automated lubrication system

### **Additional Sun Shade**

- Includes mounting hardware.

### **Electrical Outlets**

- 4 electrical (120 V) outlets located on tractor

### **HD Conveyor Chain Package**

- Includes offset link conveyor chains in lieu of standard straight links

## **EDGE™ Extended Equipment Warranty**

The EDGE™ Extended Equipment Warranty is an industry leading warranty that demonstrates our confidence in the quality and reliability of everything we make. This warranty goes above and beyond power train or extended engine warranties currently offered in the industry by covering more components and repairs as well as covering repairs done by the customer for a term of 3 years or 3,000 hours on the machine and 5 years or 6,000 hours on the engine. By covering most components other than wear items at full replacement cost and for a longer time period, the EDGE™ warranty gives owners an edge over their competition by lowering their operating costs.



# SPECIFICATIONS

## ENGINE

- RP-190/195e: Tier 4F, Cummins® QSB6.7 230 hp (172 kW) @ 1,900 rpm
- RP-190/195ex: Tier 3; Cummins® QSB6.7 230 hp (172 kW) @ 1,800 rpm\*

\* ex machines for lesser regulated countries

## WEIGHTS

- RP-190: 36,700 lbs (16,646 kg)
- RP-195: 39,220 lbs (17,789 kg)

## CHASSIS

- .75" (19 mm) thick continuous side sheets
- RP-190: 2" (51 mm) thick front cross frame member
- RP-195: 2" (51 mm) thick front cross frame member

## ELECTRICAL SYSTEM

- Two 4D batteries & 95 amp alternator
- 24v system with master disconnect switch and remote diagnostics via Roadtec Guardian™ Remote Telematics System
- Electric-over-hydraulic solenoids with manual override.

## COOLING SYSTEM

- Low noise, variable speed, hydraulically driven fan.

## PROPEL SYSTEM

- Variable-displacement hydraulic pumps
- Two-speed hydraulic motor. Direct hydraulic, single speed planetary final drives.
- Hydraulic steering wheel control (RP-190)
- Single joystick control (RP-195)

## TIRES - RP-190

- (2) hydroflated high flotation 18:00-25 sand rib drive tires
- Dual 14" (356 mm) x 22" (559 mm) front bogies

## TRACKS - RP-195

- 18" (457 mm) wide, smooth tread rubber track.

## FUME EXTRACTION SYSTEM

- Clearview FXS® fume extraction system. Clear view to the front and of the augers.

## BRAKE SYSTEM

- Hydrodynamic brakes and parking brake

## SPEED

- Paving speed:
  - 190e: 0-284 fpm (86 m/min)
  - 195e: 0-215 fpm (66 m/min)
- Travel speed: 0-12 mph (19 k/hr)
  - 190e: 0-12 mph (19 k/hr)
  - 195e: 0-7.5 (12 k/hr)

## OPERATOR STATIONS

- Hydraulic swing Comfort Drive™ operator stations. Operator stations can rotate out past edge of machine for increased visibility. Controls move with seat.
- Armrest Comfort Drive™ finger tip paver function control.

## FRONT HOPPER CAPACITY

- 13.8 ton (12.5 mt) / 252 ft<sup>3</sup> (7.1 m<sup>3</sup>) . Does not include tunnels.

## FEED SYSTEM

- Independently driven, variable-speed feeder conveyors
- 650 BHN center chromium carbide clad conveyor plates. Bolt free design. Sonic feeder control system
- Cast, 16" (406 mm) dia., 0.75" (19 mm) thick, ni-hard augers. Hydraulically raise, lower and tilt auger assembly.
- Electric flow gates for easy control of head of material

## SERVICE CAPACITIES

- Fuel Tank ..... 100 gal (379 l)
- Hydraulic Fluid Tank..... 76 gal (288 l)
- Cooling System..... 9 gal (34 l)
- DEF ..... 5 gal (18.9 l)

## NON-CONTACTING SCREED AUTOMATION

- TOPCON® sonic grade & slope control.
- MOBA® sonic grade & slope control.
- TOPCON® sonic averaging ski with hardware.
- MOBA® sonic averaging ski with hardware.

## TRACTOR

- Front wheel assist (optional)
- Hydraulic tunnel extensions (optional RP-190)

## SCREEDS

### ROADTEC S-10

- Standard, fixed-width 10' (3,048 mm) electrically-heated, vibratory screed. 32" (813 mm) long screed plate.
- Paves up to 30' (9,144 mm) wide with extensions.

### CARLSON EZIII-10

- Front extendable 10' (3,048 mm), electrically heated, vibratory screed. 26" (660 mm) long screed plate.
- Paves up to 17' (5,182 mm) wide

### CARLSON EZIV-10

- Front extendable 10' (3,048 mm), electrically heated, vibratory screed. 26" (660 mm) long screed plate.
- Paves up to 19' (5,182 mm) wide

### CARLSON EZ-R2-10

- Rear extendable 10' (3,048 mm) electrically heated, vibratory screed. 20" (508 mm) long screed plate.
- Paves up to 19'-6" (5,944 mm) wide.

### ROADTEC EAGLE® 10

- Rear extendable 10' (3,048 mm) electrically-heated, vibratory screed. 20" (508 mm) long "u" shaped, reversible, screed plate.
- Paves up to 19'-6" (5,944 mm) wide

### ALL SCREEDS

- 0.5" (12.7 mm) thick 400 Brinell® wearing surface.
- Thermostat controlled electric heat with 34 kW generator
- Standard outlets for additional lighting and accessories

## SCREED OPTIONS

### HYDRAULIC SCREED ASSIST PACKAGE

- For Eagle® screed. Constant up pressure on screed while in pave mode (forward and neutral).

### HYDRAULIC SCREED BOOST PACKAGE

- Pressurizes screed lift cylinders when paver is stopped in neutral to prevent depression in mat. Adjustable lifting pressure. Adjustable time for pressure release with forward motion (0-10 seconds).

## RP-190 (APROXIMATELY)

TRACTOR ONLY	36,700 lbs (16,646 kg) / 17'-6-3/4" (5353)
S-10	6,200 lbs (2,812 kg) / 22'-5 5/16" (6840)
CARLSON EZIII-10	6,100 lbs (2,770 kg) / 22'-7 15/16 (6907)
CARLSON EZIV-10	7,200 lbs (3,270 kg) / 22'-7 7/8" (6906)
EAGLE 10	8,200 lbs (3,720 kg) / 22'-9 3/8" (6944)

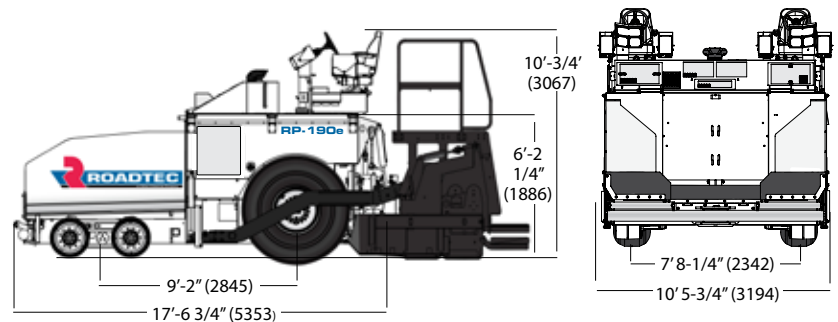

## RP-195 (APROXIMATELY)

TRACTOR ONLY	39,200 lbs (17,789 kg) / 16'-8 1/4" (5086)
S-10	6,200 lbs (2,812 kg) / 21'-11 5/16" (6688)
CARLSON EZIII-10	6,100 lbs (2,770 kg) / 21'-4 3/4" (6522)
CARLSON EZIV-10	7,200 lbs (3,270 kg) / 21'-10 1/2" (6668)
EAGLE 10	8,200 lbs (3,720 kg) / 22'-6 7/16" (6869)

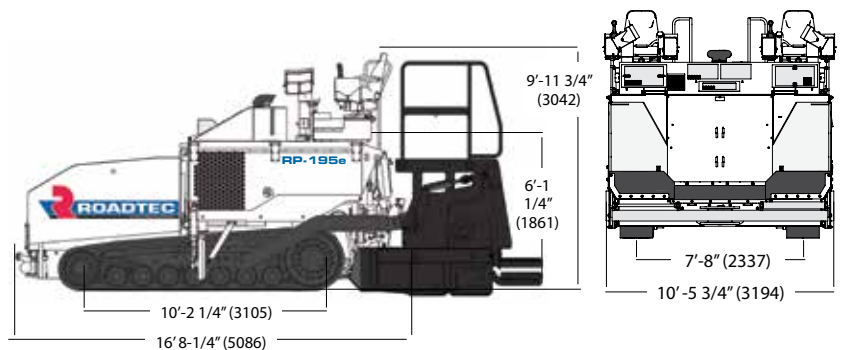

Dimensions in brackets are mm.

Specifications are subject to change without notice.



**ROADTEC.COM**

**ROADTEC** an Astec Industries Company

800 MANUFACTURERS RD • CHATTANOOGA, TN 37405 USA • 800.272.7100 • FAX 423.267.7104 • roadtec.com

2/20/15



© 2014 Roadtec, Inc. All Rights Reserved